

## MOUNTING INFORMATION

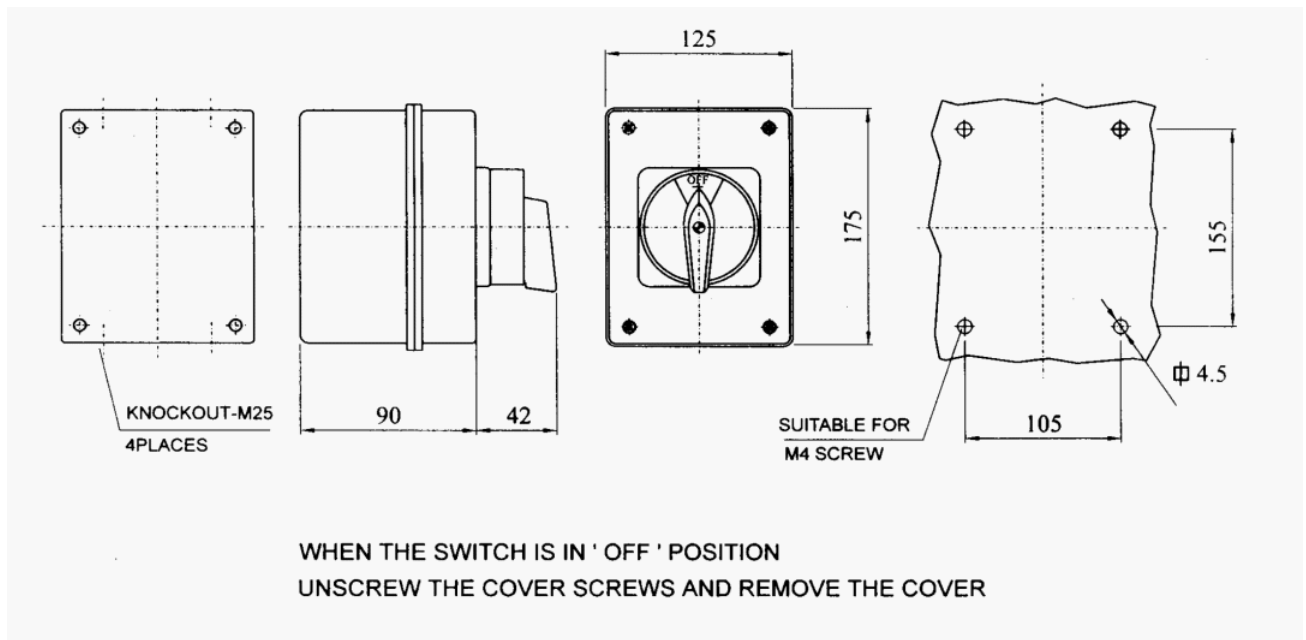

**THE ABOVE DIAGRAM GIVES ALL THE MOUNTING DIMENSIONS FOR THE SWITCH BOX. PLEASE ALSO NOTE THAT THE LID WILL ONLY COME OFF**

**WHEN ALL 4 SCREWS ARE UNDONE AND SWITCH 'A' IS IN THE OFF POSITION (SWITCH IN CENTRE OF BOX).**

## CONNECTION INFORMATION

**THE TURBINE SHOULD BE CONNECTED TO THE TOP SET OF TERMINALS IN THE SWITCH BOX. THIS IS BECAUSE THE SLOW DOWN AND STOP CIRCUIT IS ALSO CONNECTED HERE. THIS CAN BE SEEN IN THE DIAGRAM BELOW. FOR SAFETY REASONS IT IS ESSENTIAL THAT A FUSE OR DC BREAKER IS PLACED INLINE AFTER THIS BOX TO PROTECT BATTERIES OR OTHER EQUIPMENT FROM ACCIDENTAL SHORTING.**

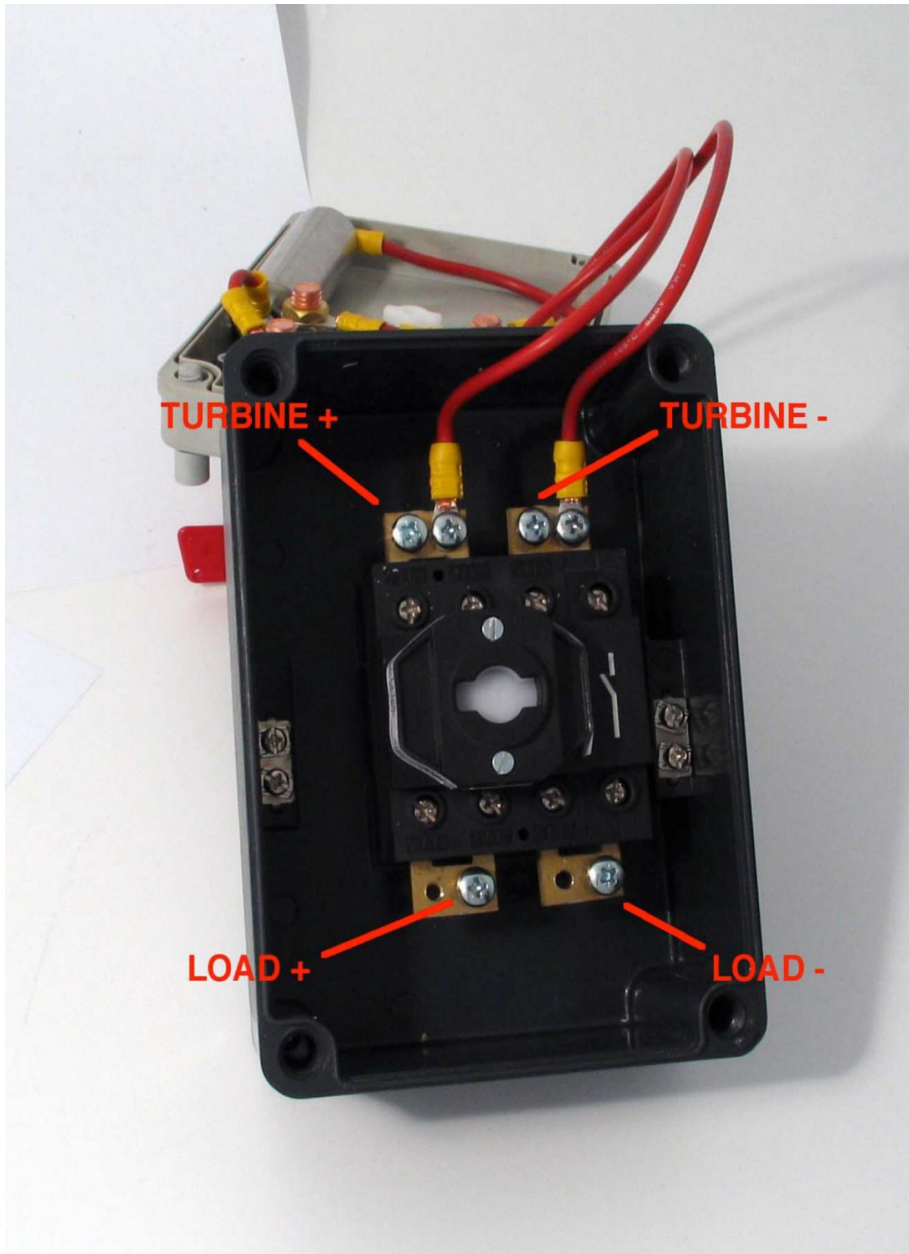

## **TURBINE STOP SEQUENCE**

**1. ROTATE SWITCH A ANTICLOCKWISE INTO THE "OFF" POSITION. THIS ISOLATES THE TURBINE FROM THE CIRCUIT IT'S CONNECTED TO I.E. BATTERY BANK OR GRID TIE INVERTER. FAILURE TO DO SO MAY RESULT IN DAMAGE WHEN STOPPING THE TURBINE AS THE + AND - OF THE TURBINE WILL BE SHORTED. This is when you find out why you installed the FUSE.....!!!**

**2. INSERT RED KEY INTO SWITCH B AND ROTATE CLOCKWISE. THIS WILL MAKE THE TURBINE SLOW DOWN TO A SAFE SPEED SO THAT IT CAN BE SHORTED AND FULLY STOPPED. THIS IS ACHIEVED BY PLACING A LOAD ON THE TURBINE VIA AN INTERNAL DUMPLoad IN THE SWITCH. THE DUMPLoad SHOULD NOT BE LEFT ENGAGED FOR LONGER THAN A**

**COUPLE OF MINUTES AS IT WILL GENERATE EXCESS HEAT IN THE SWITCH BOX.**

**3. INSERT RED KEY INTO SWITCH C AND ROTATE CLOCKWISE. THIS WILL SHORT THE OUTPUT TERMINALS OF THE TURBINE MAKING IT STOP.**

**4. TO RESTART THE TURBINE FOLLOW THE ABOVE STEPS IN REVERSE ORDER.**

**THE TURBINE SHOULD ONLY EVER BE STOPPED IN LIGHT WINDS OR WHEN THE TAIL IS FURLED.**

